

SUMMER MATH

Mrs. Sebastian's Class
Incoming 8th Grade

"It's not that I'm so smart, it's just that I stay with problems longer."
-Albert Einstein

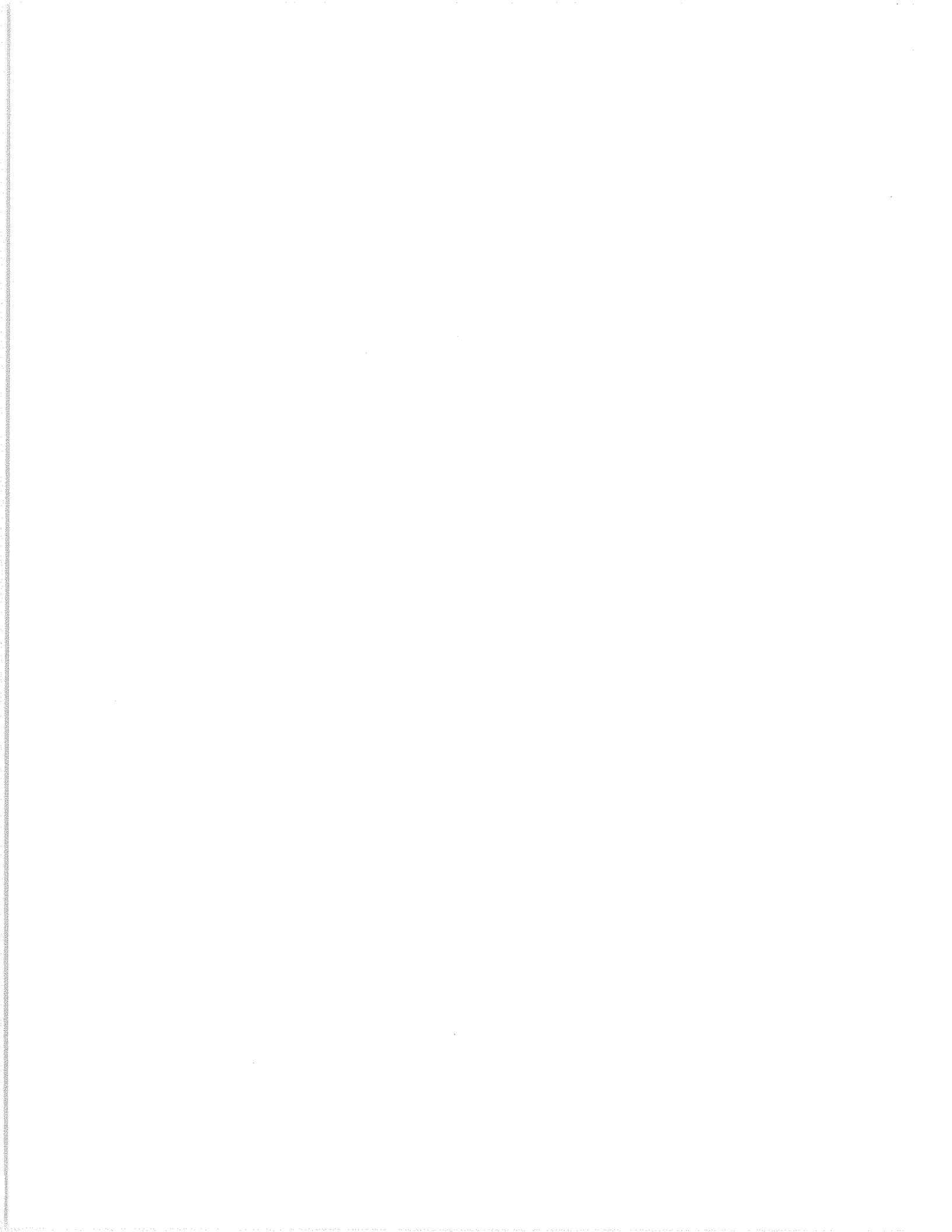

Adding Integers

- Negative + Negative:

Add the absolute values of the two numbers and make the answer negative.

ex: $-5 + (-9)$
 $5 + 9 = 14 \rightarrow \boxed{-14}$

- Negative + Positive (or Positive + Negative):

Subtract the absolute values of the two numbers (larger minus smaller) and take the sign of the number with the greater absolute value.

ex: $-7 + 12$
 $12 - 7 = 5$
 $12 > 7$, so answer is positive
 $\rightarrow \boxed{5}$

Subtracting Integers

1. Keep the first number the same
2. Change the subtraction sign to an addition sign
3. Change the sign of the second number
4. Use integer addition rules to solve the new addition problem

ex: $-3 - 9$
 $-3 + (-9) = \boxed{-12}$

ex: $-7 - (-4)$
 $-7 + 4 = \boxed{-3}$

Multiplying & Dividing Integers

1. Ignore the signs and multiply or divide as usual
2. Determine the sign of the answer using the following rules:
 - positive \times or \div positive \rightarrow positive
 - negative \times or \div negative \rightarrow positive
 - negative \times or \div positive \rightarrow negative
 - positive \times or \div negative \rightarrow negative

ex: $-3 \cdot (-5)$
 $3 \cdot 5 = 15$
negative \cdot negative \rightarrow positive $\rightarrow \boxed{15}$

ex: $48 \div (-6)$
 $48 \div 6 = 8$
positive \div negative \rightarrow negative $\rightarrow \boxed{-8}$

Find the sum or difference.

No Calculator!

1. $-80 + 77$	2. $77 + 160$	3. $-64 + (-33)$	4. $104 - (-92)$
5. $-105 - (-122)$	6. $185 - (-154)$	7. $-53 - (-59)$	8. $-6 + (-35)$
9. $15 - (-26) - (-39)$	10. $-93 + 191 + (-179)$	11. $18 + (-34) + 52$	12. $-50 - (-93) + (-17)$

Find the product or quotient.

13. $-60 \div 12$	14. $-194 \div (-2)$	15. $88 \cdot (-2)$	16. $-12 \cdot 10$
17. $-10 \cdot (-11)$	18. $90 \div (-6)$	19. $3 \cdot (-59)$	20. $-7 \cdot (-2)$
21. $-28 \cdot (-6) \div (-24)$	22. $-56 \cdot 14 \div (-8)$	23. $108 \div (-12) \cdot (-12)$	24. $-4 \cdot (-17) \div 2$

Adding & Subtracting Rational Numbers

Determine whether you should add or subtract using integer rules. Then add or subtract.

Decimals:

- Line up the decimal points
- Add or subtract and bring the decimal point down
- Use integer rules to determine the sign of the answer

ex: $-9.8 + 6.24$

neg + pos: subtract

$$\begin{array}{r} 9.80 \\ -6.24 \\ \hline 3.56 \end{array} \rightarrow \boxed{-3.56}$$

ex: $5\frac{3}{4} - (-3\frac{7}{8})$

$$\rightarrow 5\frac{3}{4} + 3\frac{7}{8}$$

pos + pos: add

$$\begin{array}{r} 5\frac{3}{4} = \frac{6}{8} \\ + 3\frac{7}{8} = \frac{7}{8} \\ \hline 8\frac{13}{8} \end{array} \rightarrow \boxed{9\frac{5}{8}}$$

Fractions/Mixed Numbers:

- Find a common denominator and then add or subtract
- Borrow or convert an improper fraction answer, if necessary
- Use integer rules to determine the sign of the answer

Multiplying & Dividing Rational Numbers

Determine the sign of the answer using integer rules. Then multiply or divide.

Multiplying Decimals:

- Ignore the decimal points. Multiply the numbers.
- Count the decimal places in the problem to determine the location of the decimal point in the answer.

ex: $-9.23 \cdot (-1.1)$

neg · neg = pos

$$\begin{array}{r} 9.23 \leftarrow 2 \text{ dec places} \\ \times 1.1 \leftarrow 1 \text{ dec place} \\ \hline 923 \\ 9230 \\ \hline 10153 \end{array} \rightarrow \boxed{10.153}$$

Dividing Decimals:

- Move the decimal in the divisor to the end of the number
- Move the decimal in the dividend the same number of places and then bring it straight up in quotient

ex: $-5.2 \div 0.2$

neg ÷ pos = neg

$$\begin{array}{r} 26 \\ 02 \overline{) 52} \end{array} \rightarrow \boxed{-26}$$

Multiplying Fractions:

- Convert mixed numbers to improper fractions.
- Cross-simplify if possible
- Multiply the numerators and multiply the denominators
- Simplify if necessary

ex: $-1\frac{3}{4} \cdot \frac{6}{14}$

neg · pos = neg

$$\rightarrow \frac{1\cancel{7} \cdot \cancel{6}^3}{2\cancel{4} \cdot \cancel{14}_2} = \frac{3}{4} \rightarrow \boxed{-\frac{3}{4}}$$

Dividing Fractions:

- Convert mixed numbers to improper fractions
- Flip the second fraction to its reciprocal and multiply the two fractions
- Simplify if necessary

ex: $-\frac{1}{2} \div (-\frac{3}{8})$

neg ÷ neg = pos

$$\rightarrow \frac{1}{2} \cdot \frac{8}{3} = \frac{4}{3} \rightarrow \boxed{1\frac{1}{3}}$$

Find the sum, difference, product, or quotient.

25. $38.61 + 36.841$	26. $1.755 - 1.23$	27. $0.71 \cdot 9.2$	28. $13.12 \div 0.1$
29. $3.651 - (-12.63)$	30. $-3.9 + (-7.6)$	31. $-14.846 \div 2.6$	32. $6 \cdot (-16.7)$
33. $26.474 - 14.527$	34. $-2.1 + 3.78$	35. $-6.15 \div (-8.2)$	36. $-12.8 \cdot (-4.88)$

Find the sum, difference, product, or quotient. Write your answer in simplest form. *No Calculator*

37. $15\frac{1}{2} + 15\frac{1}{4}$	38. $18\frac{11}{20} - 17\frac{1}{2}$	39. $3\frac{3}{7} \div 5\frac{1}{3}$	40. $4\frac{1}{2} \cdot 2\frac{2}{5}$
41. $3\frac{1}{3} - 5\frac{1}{9}$	42. $5 \cdot \left(-1\frac{2}{5}\right)$	43. $-7\frac{3}{5} + \left(-3\frac{5}{6}\right)$	44. $-2\frac{1}{12} \div \frac{3}{8}$
45. $9 \div \left(-4\frac{1}{2}\right)$	46. $-18 + 3\frac{4}{5}$	47. $2\frac{5}{6} \cdot \left(-2\frac{2}{3}\right)$	48. $-4\frac{7}{10} - 3\frac{2}{5}$

Order of Operations

Evaluate numerical expressions that contain multiple operations in the following order:

1. Grouping Symbols (complete operations in parentheses, brackets, etc.)
2. Exponents
3. Multiplication & Division (left to right)
4. Addition & Subtraction (left to right)

ex: $-2(-5 + 9)^2 - (-8) + 9$

$$-2(4)^2 - (-8) + 9$$

$$-2(16) - (-8) + 9$$

$$-32 - (-8) + 9$$

$$-24 + 9$$

$$\rightarrow \boxed{-15}$$

Evaluating Algebraic Expressions

1. Substitute the given values for the variables in the expression
2. Evaluate the expression using the order of operations

ex: evaluate

$$a - bc + b^2$$

for $a = -7$, $b = 5$, $c = -1.5$

$$-7 - (5)(-1.5) + 5^2$$

$$-7 - (5)(-1.5) + 25$$

$$-7 - (-7.5) + 25$$

$$0.5 + 25$$

$$\rightarrow \boxed{25.5}$$

Evaluate the numerical expression. Be sure to use the order of operations! *Show each step!*

49. $78 + (-2) \cdot (-56)$	50. $-65 + \frac{6}{-3} + 40$	51. $-94 - [2 - 3(24 - 12)]$	52. $43 + (-23) - (-57)$
53. $-15 - (-11) + 5 \cdot (-4)^3$	54. $-26 - (-64) + (-3)^4$	55. $-84 \div 4 + (-20)$	56. $-56 + (-50) + (-7) \cdot (-9)$
57. $-7.6 - 3 + 2.1 \cdot (-8)$	58. $-\frac{2}{3} + \frac{5}{6} \div \frac{1}{2}$	59. $-8 + 3(-2.7 + 4.23)$	60. $-3\frac{1}{2} \cdot (-2\frac{3}{4}) + (-4\frac{1}{4})$

Evaluate the algebraic expression for $a = -12$, $b = 6$, $c = -4$, and $d = 3$.

61. $a - b + c$	62. $b - cd$	63. $b(cd - a)$
64. $\frac{b}{c} - d$	65. $bd + ac$	66. $\frac{a}{d} + c^2$

One-Step Equations

- Addition Equations:

Subtract the number being added to the variable from both sides of the equation

$$\begin{array}{r} \text{ex: } y + 23 = -9 \\ \quad \quad \quad -23 \quad -23 \\ \hline \boxed{y = -32} \end{array}$$

- Subtraction Equations:

Add the number being subtracted from the variable to both sides of the equation

$$\begin{array}{r} \text{ex: } w - 13 = -5 \\ \quad \quad \quad +13 \quad +13 \\ \hline \boxed{w = 8} \end{array}$$

- Multiplication Equations:

Divide both sides of the equation by the number next to the variable

$$\begin{array}{r} \text{ex: } 6x = -18 \\ \quad \quad \quad \div 6 \quad \div 6 \\ \hline \boxed{x = -3} \end{array}$$

- Division Equations:

Multiply both sides of the equation by the number under the variable

$$\begin{array}{r} \text{ex: } \frac{h}{3} = 4.3 \\ \quad \quad \quad \cdot 3 \quad \cdot 3 \\ \hline \boxed{h = 12} \end{array}$$

Two-Step Equations

We'll learn this in 8th Grade so ignore this!

- Undo operations one at a time with inverse operations, using the order of operations in reverse (i.e. undo addition/subtraction before multiplication/division)

- Be sure to always do the same thing to both sides of the equation!

$$\begin{array}{r} \text{ex: } 7x - 4 = -32 \\ \quad \quad \quad +4 \quad +4 \\ \hline 7x = -28 \\ \quad \quad \quad \div 7 \quad \div 7 \\ \hline \boxed{x = -4} \end{array}$$

$$\begin{array}{r} \text{ex: } \frac{j}{5} + 13 = 15 \\ \quad \quad \quad -13 \quad -13 \\ \hline \frac{j}{5} = 2.5 \\ \quad \quad \quad \cdot 5 \quad \cdot 5 \\ \hline \boxed{j = 10} \end{array}$$

$$\begin{array}{r} \text{ex: } \frac{b+7}{3} \cdot 3 = -2.3 \\ \quad \quad \quad \cdot 3 \quad \cdot 3 \\ \hline b+7 = -6 \\ \quad \quad \quad -7 \quad -7 \\ \hline \boxed{b = -13} \end{array}$$

Solve the one-step equation.

67. $19 + j = -34$	68. $m - 26 = 13$	69. $\frac{x}{5} = -3$	70. $12f = 216$
71. $g - (-31) = -7$	72. $\frac{h}{q} = 13$	73. $b + (-3) = -9$	74. $-4w = -280$

Solve the two-step equation.

75. $5m - 3 = 27$	76. $7 + \frac{y}{2} = -3$	77. $4 + 3r = -8$	78. $\frac{1}{2}p - 4 = 7$
79. $\frac{k+8}{3} = -2$	80. $\frac{f}{5} - (-13) = 12$	81. $-15 - \frac{g}{3} = -5$	82. $-8 + 4m = 2$
83. $-18 - \frac{3}{4}v = 3$	84. $\frac{-5+n}{4} = -1$	85. $3.5m + 0.75 = -6.25$	86. $2y + 3 = 19$

Unit Rates

- Convert a rate to a unit rate by dividing the numerator by the denominator
 - Write your answer as a fraction with labels for the both the numerator and denominator OR as one number labeled with the first unit "per" the second unit

ex: Find the unit price:

$$\frac{\$2.99}{12 \text{ eggs}}$$

$$2.99 \div 12 \approx 0.25$$

$$\rightarrow \frac{\$0.25}{1 \text{ egg}} = \$0.25 \text{ per egg}$$

Solving Proportions

- Set cross-products equal to each other
- Solve the equation for the given variable

ex: $\frac{5}{b} = \frac{4}{10}$

$$5 \cdot 10 = 4b$$

$$\frac{50}{4} = \frac{4b}{4} \rightarrow \boxed{b = 12.5}$$

Proportion Word Problems

- Set up a ratio with what you know
- Set up a second ratio using a variable for the unknown quantity
 - Be sure that the units in the numerator match the units in the numerator of the first ratio and the units in the denominator match the units in the denominator of the first ratio.
- Make a proportion by setting the two ratios equal to each other
- Solve the proportion.

ex: A recipe calls for 2 cups of sugar for 36 cookies. How many cups of sugar are needed to make 48 cookies?

$$\frac{2 \text{ cups}}{36 \text{ cookies}} = \frac{x \text{ cups}}{48 \text{ cookies}}$$

$$2 \cdot 48 = 36x$$

$$\frac{96}{36} = \frac{36x}{36}$$

$$\boxed{x = 2\frac{2}{3} \text{ cups}}$$

Convert to a unit rate.

87. $\frac{513 \text{ miles}}{9 \text{ hours}}$	88. $\frac{180 \text{ words}}{5 \text{ minutes}}$	89. $\frac{\$2.53}{8 \text{ oz}}$
---	---	-----------------------------------

Solve the proportion.

90. $\frac{h}{6} = \frac{20}{24}$	91. $\frac{5}{7} = \frac{c}{14}$	92. $\frac{6}{8} = \frac{21}{b}$	93. $\frac{30}{j} = \frac{26}{39}$
94. $\frac{5}{k} = \frac{15}{20}$	95. $\frac{32}{112} = \frac{a}{14}$	96. $\frac{16}{7} = \frac{18}{g}$	97. $\frac{w}{60} = \frac{15}{200}$

Use a proportion to solve the word problem.

98. A cookie recipe calls for 2 eggs and 3 cups of flour. You only have 1 egg, so you have to cut the recipe. How much flour should you use?	99. Jack can run 2 miles in 15 minutes. At that rate, how far would you expect him to run in an hour?	100. Sue read 15 pages of her book in 25 minutes. At that rate, how long will it take her to read the next 10 pages?	101. The ratio of cats to dogs at the park was 1:4. If there were 12 dogs, how many cats were at the park?
102. If 2 pounds of apples cost \$2.60, how much would 5 pounds of apples cost?	103. If you burn 184 calories running 2 miles, how many calories would you burn if you run 5 miles?	104. In a shipment of 300 parts, there are 12 defective parts. How many defective parts would you expect to find in a shipment of 1,000 parts?	105. The ratio of 12-year-olds to 13-year-olds in Mr. Wu's class is 5:3. If there are 24 students in the class, how many students are 13 years old?

Solving Percent Problems

Using a Proportion:

- Set up a proportion in the following format & solve

$$\frac{\%}{100} = \frac{\text{part}}{\text{whole}}$$

Using an Equation:

- Set up an equation in the following format & then solve

$$\text{part} = \text{percent} \times \text{whole}$$

(The percent must be in decimal or fraction form in the equation!)

We usually do the equation method. "Is" means equals. "of" means multiply.

ex: 25 is what percent of 500?

$$\text{proportion: } \frac{x}{100} = \frac{25}{500} \rightarrow 500x = 2500$$

$$\text{equation: } 25 = 500x \rightarrow 0.05 = x \rightarrow x = \boxed{5\%}$$

ex: What is 15% of 88?

$$\text{proportion: } \frac{15}{100} = \frac{x}{88} \rightarrow 1320 = 100x$$

$$\text{equation: } x = 0.15(88) \rightarrow x = 13.2 \rightarrow x = \boxed{13.2}$$

ex: 18 is 30% of what number?

$$\text{proportion: } \frac{30}{100} = \frac{18}{x} \rightarrow 30x = 1800$$

$$\text{equation: } 18 = 0.3x \rightarrow 60 = x \rightarrow x = \boxed{60}$$

Percent Applications

Percent of Change

- Set up a proportion in the following format & solve

$$\frac{\%}{100} = \frac{\text{amount of change}}{\text{original amount}}$$

ex: Enrollment in 2015 was 4,850. In 2020, enrollment was 5,122. Find the percent of change.

$$\frac{x}{100} = \frac{272}{4,850}$$

$\leftarrow \begin{matrix} \text{amt of change:} \\ 5,122 - 4,850 = 272 \end{matrix}$
 $\leftarrow \text{original enrollment}$

$$\rightarrow x \approx \boxed{5.6\% \text{ increase}}$$

Tax:

- Find the amount of tax using a proportion or equation. Then add the tax to the original amount to find the total cost.

ex: Find the total cost of a \$8.95 book with 7% sales tax.

$$x = 0.07 \cdot 8.95 \rightarrow x \approx 0.63$$

$$8.95 + 0.63 = \boxed{\$9.58}$$

Discount:

- Find the amount of the discount using a proportion or equation. Then subtract that amount from the original price to find the sale price.

ex: A \$18.60 shirt is on sale for 30% off. Find the sale price.

$$\frac{30}{100} = \frac{x}{18.60} \rightarrow x \approx 5.58$$

$$18.60 - 5.58 = \boxed{\$13.02}$$

Simple Interest:

- Use the equation $I = PRT$
 - I = interest, P = principal (starting amount), R = interest rate, T = time (in years)

ex: \$5,000 is kept in an account with a 1.5% interest rate for 10 years. How much simple interest is earned?

$$I = 5,000 \cdot 0.015 \cdot 10 = \boxed{\$750}$$

\swarrow convert rate to decimal

Solve the percent problem.

106. Find 15% of 85.	107. 6 is 75% of what number?	108. 40 is what percent of 320?	109. What is 20% of 45?
110. 70 is what percent of 350?	111. Find 33.3% of 81.	112. 9 is 45% of what number?	113. What percent of 60 is 12?
114. 5% of the lights on the light string are out. If there are 100 lights on the string, how many are out?	115. There were 27 students in Jerome's class last year. This year there are 30 students in his class. Find the percent of change.	116. A \$58 camera is on sale for 20% off. Find the sale price.	117. A \$60 camera is on sale for \$50. Find the percent of change.
118. Find the total price of a \$14.00 shirt including the 7% sales tax.	119. How much simple interest is earned after 10 years if \$200 is put in an account with a 1.25% interest rate?	120. Your bill at a diner comes to \$45. If you want to leave the waitress a 20% tip, how much money should you give her?	121. Find the final price of a \$58 video game that is on sale for 15% off, after the 6.5% sales tax is included.

Probability

Probability of Simple Events

$$P(\text{event}) = \frac{\# \text{ of favorable outcomes}}{\# \text{ of possible outcomes}}$$

ex: You roll a number cube. Find $P(3)$.

When you roll a number cube, there are 6 possible outcomes:
(1, 2, 3, 4, 5, or 6)

There is 1 favorable outcome: (rolling a 3)

$$\rightarrow P(3) = \boxed{\frac{1}{6}}$$

Probability of Compound Events

- Independent Events

$$P(A \text{ and } B) = P(A) \cdot P(B)$$

ex: You roll 2 number cubes. Find $P(3, \text{ odd})$.

$$P(3) \cdot P(\text{odd}): \frac{1}{6} \cdot \frac{3}{6} = \boxed{\frac{1}{12}}$$

- Dependent Events

$$P(A \text{ then } B) = P(A) \cdot P(B \text{ after } A)$$

Future learning \ddot{u}

ex: There are 3 red crayons and 4 blue crayons in a bag. You pick one out without looking, do not replace it, and then pick another. Find $P(\text{red, red})$

$P(\text{red}) \cdot P(\text{red after picking red})$:

$$\frac{3}{7} \cdot \frac{2}{6} = \boxed{\frac{1}{7}}$$

Angle Relationships

- Adjacent Angles: angles that share a vertex and a common side

ex:

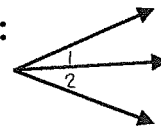

$\angle 1$ and $\angle 2$ are adjacent because they share a vertex and side.

- Complementary Angles: angles with a sum of 90°

ex:

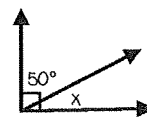

The angles are complementary because they form a right angle, so $50 + x = 90$
 $\rightarrow \boxed{x = 40^\circ}$

- Supplementary Angles: angles with a sum of 180°

ex:

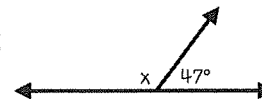

The angles are supplementary because they form a line, so $x + 47 = 180$
 $\rightarrow \boxed{x = 133^\circ}$

- Vertical Angles: a pair of opposite angles formed where two lines intersect. Vertical angles are congruent.

ex:

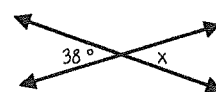

The angles are vertical because they are across from each other, so $\boxed{x = 38^\circ}$

A bag of marbles contains 8 blue marbles, 6 red marbles, and 4 green marbles. Find the probability of each event if you choose marbles without looking in the bag.

122. P(green)	123. P(red)	124. P(blue)	125. You pick a marble, <u>replace it</u> , and then pick another. Find P(blue, blue).
126. You pick a marble, <u>replace it</u> , and then pick another. Find P(red, green).	127. You pick a marble, <u>do not replace it</u>, and then pick another. Find P(blue, blue).	128. You pick a marble, <u>do not replace it</u>, and then pick another. Find P(red, green).	129. You pick a marble, <u>do not replace it</u>, and then pick another. Find P(green, green).

Identify the relationship between $\angle 1$ and $\angle 2$.

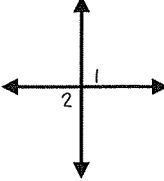
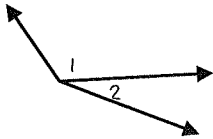
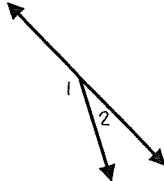
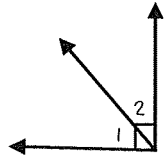
130. 	131. 	132. 	133. 
---	---	--	---

Find the value of x .

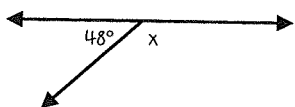
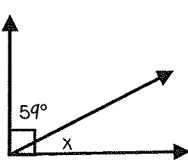
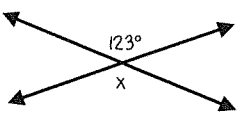
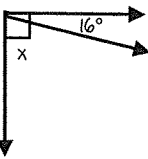
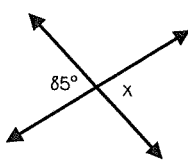
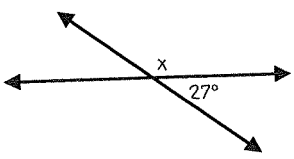
134. 	135. 	136. 
137. 	138. 	139. 

2-Dimensional Geometry Formulas

- Perimeter is the distance around a polygon
 - Perimeter of Any Figure: $P = \text{sum of side lengths}$
- Circumference is the distance around a circle
 - $C = \pi d$
- Area is the space inside a figure
 - Area of Parallelogram: $A = bh$
 - Area of Triangle: $A = \frac{1}{2}bh$
 - Area of Trapezoid: $A = \frac{1}{2}h(b_1 + b_2)$
 - Area of Circle: $A = \pi r^2$

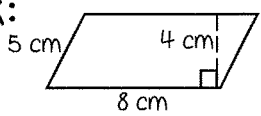
ex:  $P = 5 + 8 + 5 + 8$
 $\rightarrow P = 26 \text{ cm}$
 $A = 8 \cdot 4$
 $\rightarrow A = 32 \text{ cm}^2$

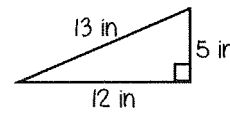
ex:  $P = 5 + 12 + 13$
 $\rightarrow P = 30 \text{ in}$
 $A = \frac{1}{2} \cdot 5 \cdot 12$
 $\rightarrow A = 30 \text{ in}^2$

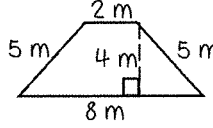
ex:  $P = 5 + 2 + 5 + 8$
 $\rightarrow P = 20 \text{ m}$
 $A = \frac{1}{2} \cdot 4(2 + 8)$
 $\rightarrow A = 20 \text{ m}^2$

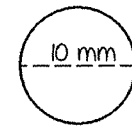
ex:  $C = 10 \cdot \pi$
 $\rightarrow C \approx 31.4 \text{ mm}$
 $A = \pi \cdot 5^2$
 $\rightarrow A \approx 78.5 \text{ mm}^2$

Abbreviations used in Formulae:

P = perimeter, C = circumference, d = diameter, b = base, h = height, r = radius

3-Dimensional Geometry Formulas

- Volume is the capacity of a 3-dimensional figure
 - Volume of Rectangular Prism: $V = lwh$
 - Volume of Cylinder: $V = \pi r^2 h$
- Surface Area is the sum of the areas of all the faces on a 3-dimensional figure
 - Surface Area of Rectangular Prism:
 $SA = 2lw + 2lh + 2wh$
 - Surface Area of Cylinder: $SA = 2\pi r^2 + 2\pi rh$

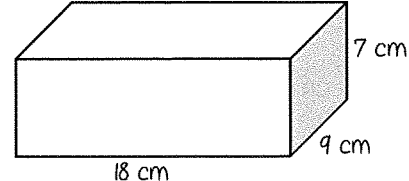
ex:  $V = 18 \cdot 9 \cdot 7$
 $\rightarrow V = 1,134 \text{ cm}^3$
 $SA = 2 \cdot 18 \cdot 9 + 2 \cdot 9 \cdot 7 + 2 \cdot 18 \cdot 7$
 $\rightarrow SA = 702 \text{ cm}^2$

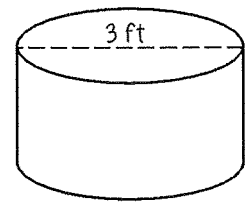
ex:  $V = \pi \cdot 1.5^2 \cdot 2$
 $\rightarrow V \approx 14.1 \text{ ft}^3$
 $SA = 2 \cdot \pi \cdot 1.5^2 + 2 \cdot \pi \cdot 1.5 \cdot 2$
 $\rightarrow SA \approx 33.0 \text{ ft}^2$

Abbreviations used in Formulae:

V = volume, SA = surface area, l = length, w = width, h = height, r = radius

Find the perimeter (or circumference) and area of the given shape. Round to the nearest tenth if necessary.

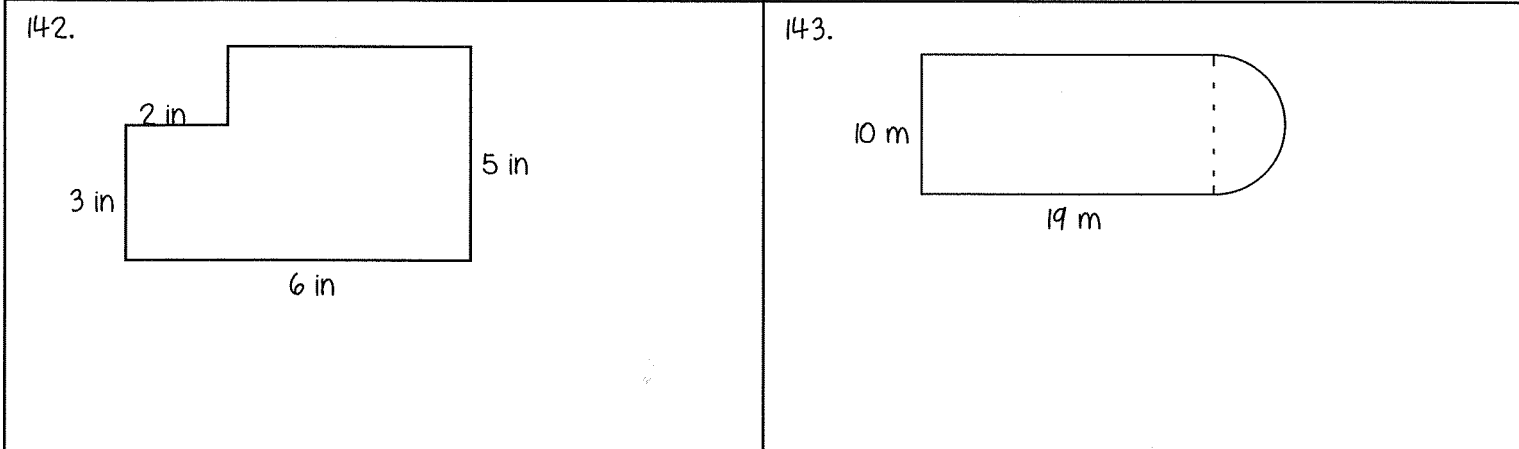
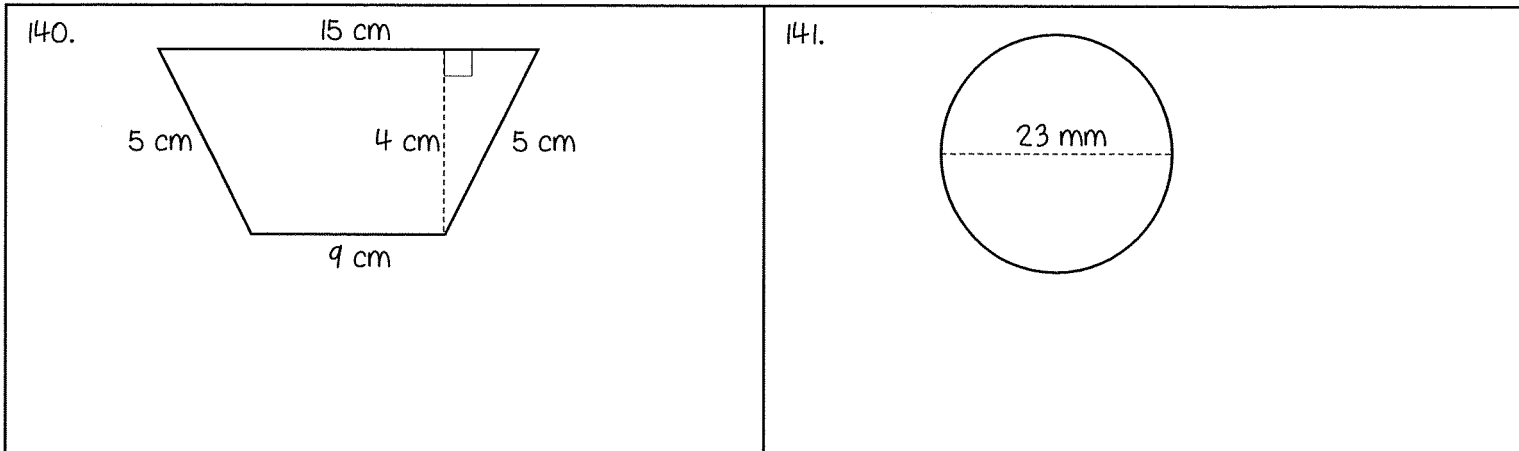

Find the ~~surface area and~~ volume of the given figure. Round to the nearest tenth if necessary. *Just find volume. Use formulas from page before.*

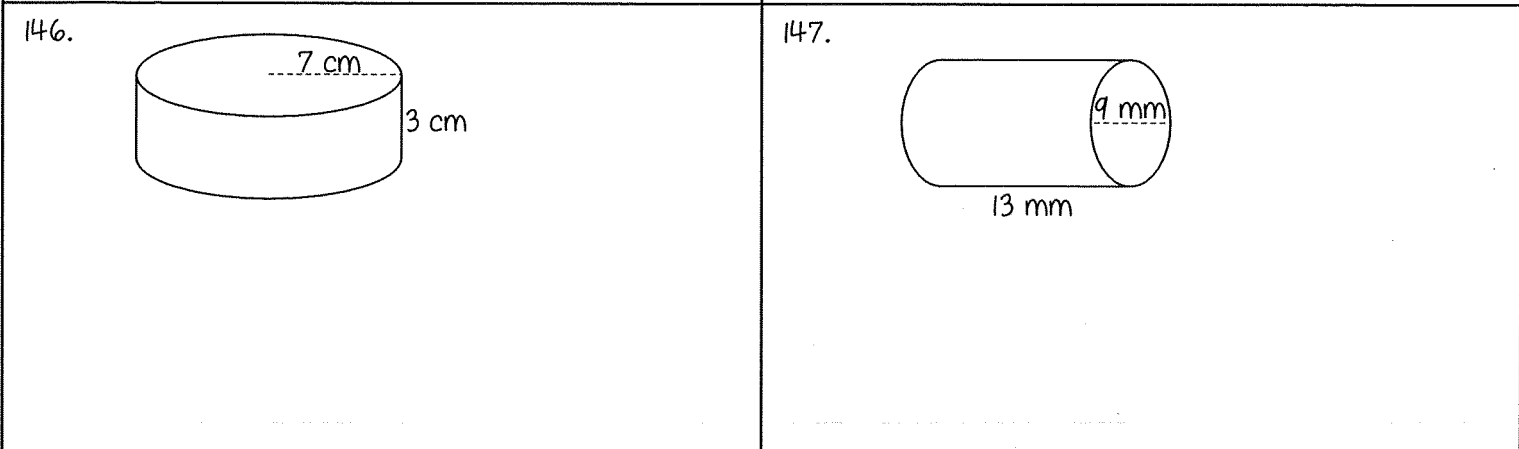
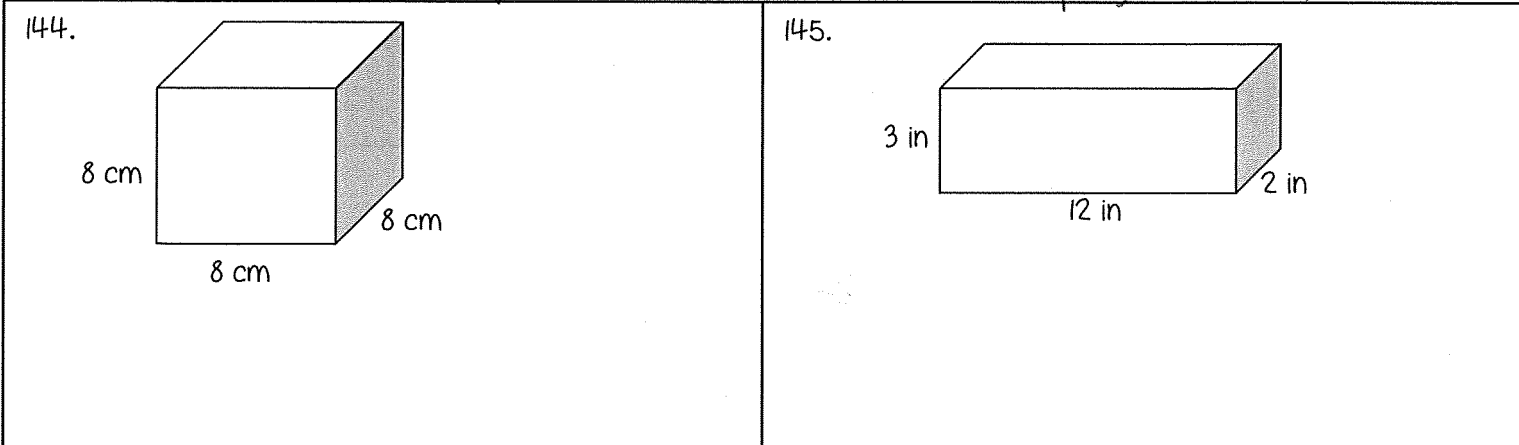

Integer Worksheet 1 *No calculator!*

Complete each problem *WITHOUT* using your calculator.
Write each quotient as a fraction or mixed number if it is not an integer.

Addition	Subtraction	Multiplication	Division
1) $-8 + +2 =$ _____	11) $-8 - +2 =$ _____	21) $-8 \cdot +2 =$ _____	31) $-8 \div +2 =$ _____
2) $+2 + -7 =$ _____	12) $+2 - -7 =$ _____	22) $+2 \cdot -7 =$ _____	32) $+2 \div -7 =$ _____
3) $-9 + -4 =$ _____	13) $-9 - -4 =$ _____	23) $-9 \cdot -4 =$ _____	33) $-9 \div -4 =$ _____
4) $+8 + -3 =$ _____	14) $+8 - -3 =$ _____	24) $+8 \cdot -3 =$ _____	34) $+8 \div -3 =$ _____
5) $+6 + +2 =$ _____	15) $+6 - +2 =$ _____	25) $+6 \cdot +2 =$ _____	35) $+6 \div +2 =$ _____
6) $+9 + -8 =$ _____	16) $+9 - -8 =$ _____	26) $+9 \cdot -8 =$ _____	36) $+9 \div -8 =$ _____
7) $+6 + -3 =$ _____	17) $+6 - -3 =$ _____	27) $+6 \cdot -3 =$ _____	37) $+6 \div -3 =$ _____
8) $-7 + +6 =$ _____	18) $-7 - +6 =$ _____	28) $-7 \cdot +6 =$ _____	38) $-7 \div +6 =$ _____
9) $+8 + +5 =$ _____	19) $+8 - +5 =$ _____	29) $+8 \cdot +5 =$ _____	39) $+8 \div +5 =$ _____
10) $-2 + +8 =$ _____	20) $-2 - +8 =$ _____	30) $-2 \cdot +8 =$ _____	40) $-2 \div +8 =$ _____

Integer Worksheet 2 *No Calculator!*

Complete each problem *WITHOUT* using your calculator.
Write each quotient as a fraction or mixed number if it is not an integer.

Addition	Subtraction	Multiplication	Division
1) $-1 + -1 =$ _____	11) $-1 - -1 =$ _____	21) $-1 \cdot -1 =$ _____	31) $-1 \div -1 =$ _____
2) $-1 + -4 =$ _____	12) $-1 - -4 =$ _____	22) $-1 \cdot -4 =$ _____	32) $-1 \div -4 =$ _____
3) $+9 + +8 =$ _____	13) $+9 - +8 =$ _____	23) $+9 \cdot +8 =$ _____	33) $+9 \div +8 =$ _____
4) $+6 + -8 =$ _____	14) $+6 - -8 =$ _____	24) $+6 \cdot -8 =$ _____	34) $+6 \div -8 =$ _____
5) $+6 + +8 =$ _____	15) $+6 - +8 =$ _____	25) $+6 \cdot +8 =$ _____	35) $+6 \div +8 =$ _____
6) $-5 + -9 =$ _____	16) $-5 - -9 =$ _____	26) $-5 \cdot -9 =$ _____	36) $-5 \div -9 =$ _____
7) $-5 + -1 =$ _____	17) $-5 - -1 =$ _____	27) $-5 \cdot -1 =$ _____	37) $-5 \div -1 =$ _____
8) $+4 + +6 =$ _____	18) $+4 - +6 =$ _____	28) $+4 \cdot +6 =$ _____	38) $+4 \div +6 =$ _____
9) $+2 + +5 =$ _____	19) $+2 - +5 =$ _____	29) $+2 \cdot +5 =$ _____	39) $+2 \div +5 =$ _____
10) $-8 + -2 =$ _____	20) $-8 - -2 =$ _____	30) $-8 \cdot -2 =$ _____	40) $-8 \div -2 =$ _____